



## Scope of Modelling and Control of an FCC Unit

\*Neha

**ABSTRACT-** Fluid catalytic cracking (FCC) is an essential process for the conversion of gas oil to gasoline. model uses three lump kinetics to describe the cracking reactions in the riser considered as a plug-flow system. The riser behavior is described by gasoil, gasoline, coke and energy balances as a plug flow reactor. The separator is considered as a CSTR. The regenerator mainly constituted by a dense and a dilute zone is also considered as a CSTR to represent the catalyst and its dynamic behavior is described by coke, oxygen and energy balances.

This model is sufficiently complex to capture the major dynamic effects that occur in a FCC and to control the key variables which are the riser outlet temperature and the regenerator dense bed temperature. The manipulated inputs are the air inlet flow rate in the regenerator and the regenerated catalyst flow rate. Hard constraints are imposed with respect to the manipulated variables. In spite of the important nonlinearity of the FCC, Model Predictive Control is able to maintain a smooth multivariable control of the plant, while taking into account the constraints

**Keywords:** *FCC, riser, regenerator, dense bed, dilute bed, five lump kinetics.*

### Introduction

**Petro FCC Process:** The Petro FCC process targets the production of petrochemical feedstock rather than fuel products. This new process, which utilizes a uniquely designed FCC unit, can produce very high yields of light olefins and aromatics when coupled with aromatics complex. The catalyst section of the Petro FCC process uses a high-conversion, short-contact time reaction zone that operates at elevated reactor riser outlet temperatures.

Refineries vary by complexity; more complex refineries have more secondary conversion capability, meaning they can produce different types of petroleum products. Fluid catalytic cracking (FCC), a type of secondary unit operation, is primarily used in producing additional gasoline in the refining process.

Unlike atmospheric distillation and vacuum distillation, which are physical separation processes, fluid catalytic cracking is a chemical process that uses a catalyst to create new, smaller molecules from larger molecules to make gasoline and distillate fuels.

The catalyst is a solid sand-like material that is made fluid by the hot vapor and liquid fed into the FCC (much as water makes sand into quicksand). Because the catalyst is fluid, it can circulate around the FCC, moving between reactor and regenerator vessels (see photo). The FCC uses the catalyst and heat to break apart the large molecules of gas oil into the smaller molecules that make up gasoline, distillate, and other higher-value products like butane and propane. After the gas oil is cracked through contact with the catalyst, the



resulting effluent is processed in fractionators, which separate the effluent based on various boiling points into several intermediate products, including butane and lighter hydrocarbons, gasoline, light gas oil, heavy gas oil, and clarified slurry oil.

Diagram of the fluid catalytic cracking process

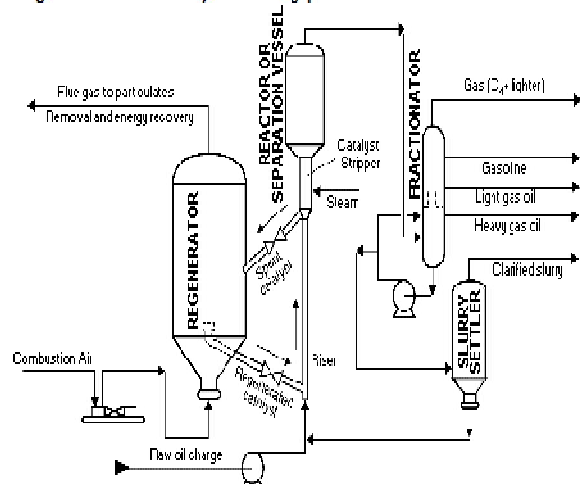

The butane and lighter hydrocarbons are processed further to separate them into fuel gas (mostly methane and ethane), propane, propylene, butane, and butene for sale, or for further processing or use. The FCC gasoline must be desulfurized and reformed before it can be blended into finished gasoline; the light gas oil is desulfurized before blending into finished heating oil or diesel; and the heavy gas oil is further cracked in either a hydrocracker (using hydrogen and a catalyst) or a coker. The slurry oil can be blended with residual fuel oil or further processed in the coker.

Carbon is deposited on the catalyst during the cracking process. This carbon, known as catalyst coke, adheres to the catalyst, reducing its ability to crack the oil. The coke on the spent catalyst is burned off, which reheats the catalyst to add heat to the FCC process. Regeneration produces a flue gas that passes through environmental control

equipment and then is discharged into the atmosphere.

**A modern FCC catalyst has four major components:**

- crystalline zeolite
- matrix,
- binder
- filler.

**Major primary reactions taking place in catalytic cracking**

- Paraffins → Smaller paraffins + olefins
- Alkyl naphthene → naphthene + olefin
- Alkyl aromatic → aromatic + olefin

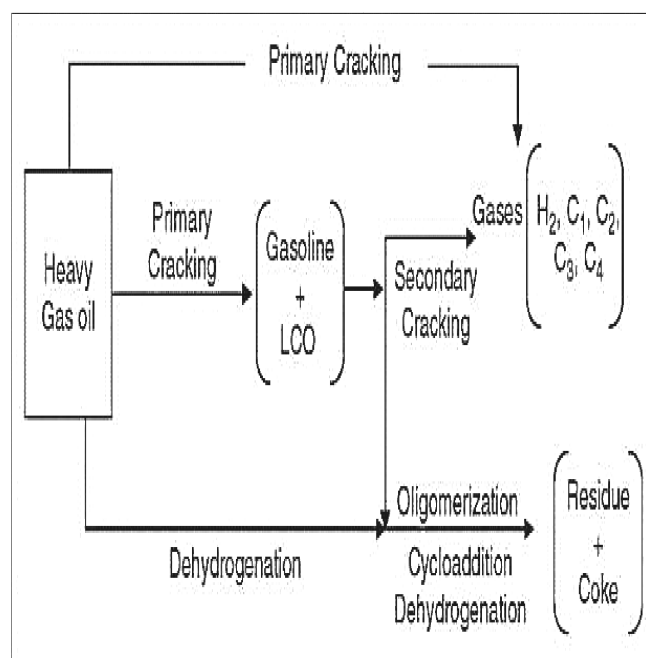



### [Reactions pathways in FCC]

- The cracking of a carbon-carbon bond
- Isomerization
- Hydrogen transfer

## FCC Chemistry

The main reaction in the FCC is the catalytic cracking of paraffin, olefins, naphthenes and side chains in aromatics. A network of reactions occurring in the FCC is illustrated in Figure. The VGO undergoes the desired 'primary cracking' into gasoline and LCO. A secondary reaction also occurs, which must be limited, such as hydrogen transfer reaction which lowers the gasoline yield and causes the cyclo-addition reaction.

### Process Steps

Three basic functions in the catalytic cracking process are:

**Reaction** - Feedstock reacts with catalyst and cracks into different hydrocarbons;

**Regeneration**- Catalyst is reactivated by burning off coke; and recirculated to reactor

**Fractionation** -Cracked hydrocarbon stream is separated into various products like LPG and gasoline, like light cycle oil and heavy cycle oil are withdrawn a

**The three dominant reactions of carbenium ions are:**

Cracking, isomerization, and hydrogen transfer reactions account for the majority of cat cracking reactions. Other reactions play an important role in unit operation. Two prominent reactions are dehydrogenation and coking.

**Dehydrogenation:** Under ideal conditions (i.e., a "clean" feedstock and a catalyst with no metals), cat cracking does not yield any appreciable amount of molecular hydrogen. Therefore, dehydrogenation reactions will proceed only if the catalyst is contaminated with metals such as nickel and vanadium.

**Coking:** Cat cracking yields a residue called coke. The chemistry of coke formation is complex and not very well understood. Similar to hydrogen transfer reactions, catalytic coke is a "bimolecular" reaction. It proceeds via carbenium ions or free radicals. In theory, coke yield should increase as the hydrogen transfer rate is increased. It is postulated that reactions producing unsaturates and multi-ring aromatics are the principal coke-forming compounds. Unsaturates such as olefins, diolefins, and multi-ring polycyclic olefins are very reactive and can polymerize to form coke.

**The main reactions in the FCC reactor can be summarized as follows:**

#### I. Paraffins

- Thermal catalytic cracking  
Paraffin cracking →  
Paraffins + Olefins



## II. Olefins

The following reaction can occur with olefins:

- Olefin cracking  $\longrightarrow$  LPG olefins
- Olefin cyclisation  $\longrightarrow$  Naphthenes
- Olefin isomerization  $\longrightarrow$  Branched olefins + Branched paraffins
- Olefin H-transfer  $\longrightarrow$  Paraffins
- Olefin cyclisation  $\longrightarrow$  Coke

## III. Naphthenes

- Naphthene cracking  $\longrightarrow$  Olefins
- Naphthene dehydrogenation  $\longrightarrow$  Aromatics
- Naphthene isomerization  $\longrightarrow$  Restructured naphthenes

## IV. Aromatics

- Aromatics (side chain)  $\longrightarrow$  Aromatics + Olefins
- Aromatic trans alkylation  $\longrightarrow$  Alkyaromatics
- Aromatic dehydrogenation  $\longrightarrow$  Polyaromatics + Coke

## FCC model

The feed which comprises a blended mixture of vacuum gas oil and heavy gas oil enters at the bottom of riser reactor through feed nozzle system with optimum atomization of feed. The liquid feed droplets come in direct contact with hot catalyst particles from the regenerator and are vaporized. These vapours along with catalyst particles move upwards along the riser height and at the same time vapour feed also starts cracking. The cracking reactions taking place in the riser are endothermic. The catalytic reactions occur in vapour phase. The rate of vaporization of feed in the entry zone of the riser reactor affects the cracking performance of the feed to a great extent. The cracking reaction terminates in the riser reactor because of the deactivation of the catalyst due to coke deposition on the catalyst surface as well as the short contact time between catalyst and vapour hydrocarbons in the riser reactor.

## Regenerator Modelling

The deactivated catalyst, after steam stripping of hydrocarbons, enters the regenerator where all hydrogen in the coke is converted into steam. Carbon can be converted to either CO or CO<sub>2</sub>. The heat of combustion raises the temperature of the

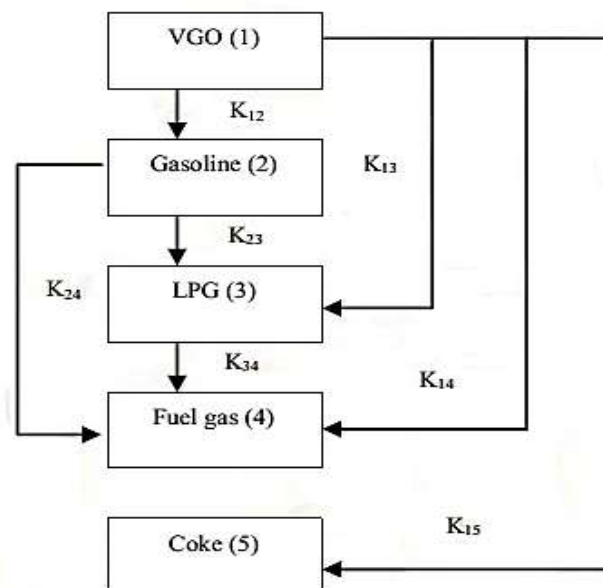



catalyst recycling from the regenerator. The heat of combustion released in the regenerator is therefore the most critical item in any such simulation.

### Five Lump Kinetic Scheme

The desirable properties of an FCC catalyst are:

- Good stability to high temperature and to steam
- High activity
- Large pore sizes
- Good resistance to attrition
- Low coke production

- Significant scope exists in the refinery in Asia region to enhance the production of propylene in Asia region .
- Maximizing propylene yield from FCC is typically accomplished by combining a low rare earth catalyst system with severe reaction condition Some of the olefin maximizing technology are deep catalytic cracking (DCC) based on riser bed catalytic cracking,

### REFERENCES

M.A. Fahim, T.A. Al-Sahhaf& A.S. Elkilani, *“Fundamentals of Petroleum Refining,” 1<sup>st</sup> ed., 2010 (Elsevier).*

Robert A. Meyers, *“Handbook of Petroleum Refining Process,” 3<sup>rd</sup> ed. (McGraw-Hill)*

D. Kunii, O. Levenspiel, *“Fluidization Engineering,” 2<sup>nd</sup> ed., 1991 (Butterworth–Heinemann, London).*

Prabha K.Dasila et al, *“Parametric Sensitivity Studies in a Commercial FCC Unit,” Advances in Chemical Engineering and Science, 2012, 2, 136-149.*

MehranHeydari et al, *“Study of Seven-Lump Kinetic Model in the Fluid Catalytic Cracking Unit,” American Journal of Applied Sciences, 2010, 7 (1), 71-76.*

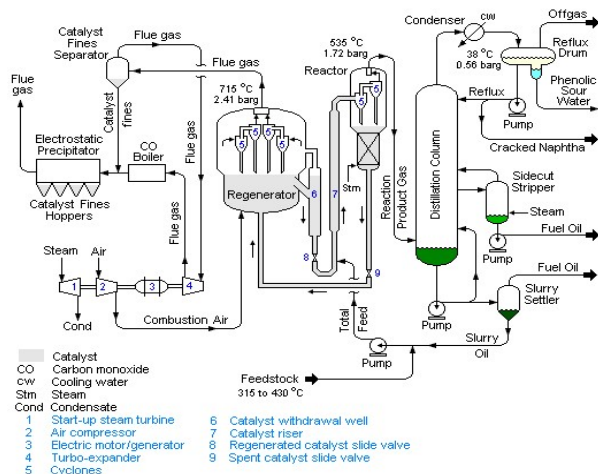

[schematic flow diagram of a Fluid Catalytic Cracking unit as used in petroleum refineries]

### Scope in FCC

- Maximize the yield of propylene due to growing demand of propylene.



K. K. Dagde, Y. T. Puyate, “ *Modelling And Simulation Of Industrial FCC Unit: Analysis Based On Five-Lump Kinetic Scheme For Gas-Oil Cracking,*” International Journal of Engineering Research and Applications , 2012, Vol. 2, Issue 5, 698-714.

Vijay Kumar Koratiya et al, “*MODELING, SIMULATION AND OPTIMIZATION OF FCC DOWNER REACTOR,*” Petroleum & Coal, 2010, 52(3), 183-192.

ArnonArbelet al, “*Dynamics and Control of Fluidized Catalytic Crackers: 3. Designing the Control System: Choice of Manipulated and Measured Variables for Partial Control,*”Ind. Eng. Chem. Res., 1996,35,2215-2233.

H.A. Affum et al, “*Modeling Conversion in a Fluid Catalytic Cracking Regenerator in Petroleum Refining,*” Research Journal of Applied Sciences, Engineering and Technology, 2011, 3(6), 533-539.

G.M. Bollas et al, “*Integrated FCC riser—regenerator dynamics studied in a fluid catalytic cracking pilot plant,*” Chemical Engineering Science, 2007,62, 1887 – 1904.